

Cost reduction through innovation.



VARIOCENTROL



„Our expertise in surface covering compaction technology is second-to-none and our research never ceases. Our philosophy is: if we stop trying to be the best we will no longer be the best.“

Robert Laux
Head of Technology.





B for BOMAG – B for Best Compaction.

Just consider this: an intelligent system that improves compaction efficiency, saves time and energy, reduces the need for conventional compliance testing, provides compaction documentation and increases the versatility of your single drum roller. This is exactly what BOMAG VARIOCONTROL does – and it has been proven many times over on site.

System solutions such as VARIOCONTROL have made BOMAG the leading provider of compaction technology for surface covering dynamic compaction control in the world today.

Increasing quality specifications, rising costs and raw material prices mean contractors are facing ever-higher risks. Contractors often incur higher

costs due to additional preventative work, when using conventional compaction equipment. This reduces profit and competitiveness when tendering for contracts, and does not eliminate the risks associated with much construction work. The solution is the intelligent BOMAG VARIOCONTROL system for single drum rollers.

Contents:

| | |
|--|----|
| Innovation. Optimum compaction power at all times. | 4 |
| Efficiency. BOMAG precision. How does VARIOCONTROL work? | 6 |
| Technology. Compaction is controlled: The measuring technology. | 8 |
| Profitability. Project cost calculations. | 10 |



Optimum compaction power at all times.

VARIOCONTROL on BOMAG single drum rollers automatically optimises compaction forces in response to the current soil status. The stiffness of the soil under the drum is measured many times a second. These results then serve as the basis in calculating the force needed to achieve optimum compaction.



BOMAG single drum rollers with BVC: equally suited to urban use as to heavy-duty applications such as rockfill.

Compaction force is automatically and continuously adjusted at a given speed to match the soil requirements. This applies to all soil and rock construction materials. Compaction energy is adjusted by a specially designed exciter system, which changes the vibrating direction of the drum. The angle ranges from purely horizontal vibration for highly sensitive surface compaction to vertical vibration for maximum depth penetration.

VARIOCONTROL is operated using a display on which the driver sets the target compaction value; this setting is then automatically controlled by the system. During operation, the system clearly signals when no further passes are required. This avoids over-compaction of the soil or unwanted drum bounce.



The result:

- ◆ Higher compaction output (m³/h)
- ◆ Enhanced depth effect
- ◆ Uniform compaction
- ◆ Early detection of weak spots
- ◆ Better surface quality
- ◆ Avoidance of over-compaction
- ◆ Reduction of unwanted vibration
- ◆ Fewer passes



BOMAG single drum rollers – VARIOCONTROL increases utilisation.

VARIOCONTROL models come in four weight classes:

- ◆ BW 177 BVC (7,3 t)
- ◆ BW 213 DH BVC (14,6 t)
- ◆ BW 226 DH BVC (26 t)
- ◆ BW 332 DI BVC (32 t)

Infinitely adjustable vibration creates a range of amplitudes. This means that one single drum roller can be used for a wide variety of compaction work. If vibration is applied horizontally, for example, heavy-duty rollers can be used in urban surroundings or near buildings. VARIOCONTROL means the amplitude is adjusted exactly to the environment. The surrounding area is protected against unwanted vibration, without loss of compaction performance. When amplitude is increased to maximum the roller not only performs within its own weight class, but is also capable of handling applications normally associated with heavier rollers.

By way of example, the BW 213 DH-4 BVC with directed vibration produces an amplitude of 2.5 mm. This is 25% higher than comparable standard rollers using a circular exciter. With VARIOCONTROL thicker layers can be compacted or on an unchanged layer thickness in less passes.

And VARIOCONTROL can do more ... Every roller driver knows the problem: on some materials a bow-wave is created in front of the drum. VARIOCONTROL automatically switches the direction of vibration to the travel direction. This ensures that the material is always drawn under the drum and also improves roller traction.

Minimum amplitude is automatically triggered at standstill – so sinking the roller drum in soft material is effectively prevented.



BW 332 DI BVC.



BW 213 DH BVC.



BW 226 DI BVC with polygonal drum.

BOMAG precision: How does VARIOCONTROL work?

Only BOMAG produces vibration using directed oscillation with the VARIO exciter system in the drum. The exciter consists of counter-rotating eccentric weights.

Individual centrifugal forces overlap due to counter-directional rotation, so that the resulting force is only effective at one level. This generates directed vibration: the direction of vibration is changed by re-orienting the entire exciter unit. The drum can vibrate vertically or horizontally, or at any angle in between. Changing the direction of vibration is equivalent to changing the amplitude and with it the compaction energy introduced into the ground.

Two acceleration transducers continuously measure the movement of the drum on the soil to calculate the optimum amplitude. This signal is then used to calculate the dynamic soil stiffness „ E_{VIB} “ in MN/m². If the dynamic stiffness of the soil – in other words the compaction – increases, the ground contact force will also increase. The movement of the drum changes and is recognised by the sensors. Optimum amplitude is calculated and the system adjusts in micro-seconds using these measurements.

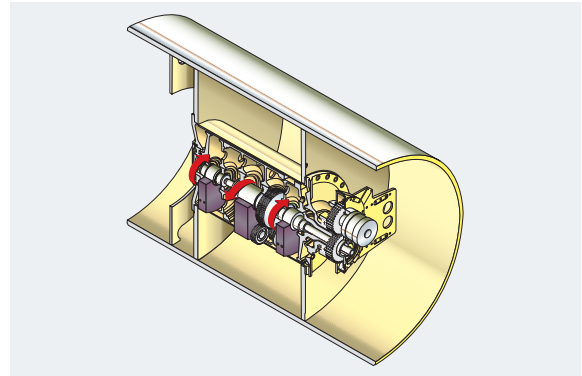

BVC directed vibrator.



Horizontal direction = minimum compaction energy = surface compaction.



Angle = adjusted compaction energy.



Vertical direction = maximum compaction energy = increased depth effect.



Ready for any job: automatic and manual settings

Automatically better compaction: the automatic function

With VARIOCONTROL automatic mode the driver selects a target E_{VIB} value in MN/m^2 . E_{VIB} has a direct correlation to EV_1 and EV_2 in the plate load test. The automatic system continuously compares current results with the target value. If the variation is large, the system automatically uses high amplitude. This produces quick results and high efficiency especially at the beginning of compaction. The amplitude is reduced as the values approach the target. This gives uniform compaction over the entire area, even when initial conditions are not homogenous. The automatic system also avoids over-compaction, which can loosen the surface and destroy the soil structure. Once the target value has been achieved, or when no further compaction is possible, the driver is informed through the display and unnecessary passes are avoided.

Targeted manual compaction: Manual function

With manual mode on VARIOCONTROL, the driver specifies a fixed amplitude. The system offers six settings from 0 to maximum. The amplitude is maintained constantly at the chosen value; there is no adjustment to the measured E_{VIB} value. Manual mode is chosen, for example, if the vibration impact on the surrounding areas needs to be limited. Vibration can cause considerable damage in urban areas or above underground pipework. Conventional rollers can frequently only be used with static compaction. However, BOMAG VARIOCONTROL gives optimum compaction with minimal impact on the surrounding area.

Limiting the amplitude

In automatic mode the maximum amplitude can be limited. This function is particularly useful when working on thin layers (e.g. frost blankets), as the roller will only compact down to the desired depth and so achieves a uniform density.



The clear screen display (differs from the BW 177 BVC design) tells the driver when optimum compaction is reached.

Compaction is controlled: the measuring technology.

With the E_{VIB} measured value in MN/m^2 , the user has, for the first time, a meaningful indicator irrespective of the type of roller used or other influences.

Surface covering compaction control: Documentation

BTM prof

VARIOCONTROL single drum rollers are equipped with the BOMAG TERRAMETER BTM prof measuring system as standard. The BTM prof also includes visualisation of the current E_{VIB} value through a display and printer. The display shows this value as a numerical value and as a bar chart. The printer can be used to document the course of the E_{VIB} value track by track. Weak spots are detected early on.

The simple answer: BCM 05

BOMAG COMPACTION MANAGEMENT BCM 05 supplies convenient documentation of results.

BCM 05 is a construction site compatible tablet PC for storing E_{VIB} values. No need for printouts. The entire area to be compacted is displayed on the PC. Measured E_{VIB} values are displayed as line charts and colour intervals. The colour intervals can be chosen as required, so that both compaction progress and weak spots can be clearly identified during work. Data can be transferred by USB stick to a fixed PC for analysis and documentation using the BCM 05 office software. The following is documented in addition to E_{VIB} :

- ◆ the number of passes
- ◆ the amplitude
- ◆ the frequency and working speed



Compaction is now fully under control – BOMAG measuring technology, easy to operate and centrally controlled.

Technological progress – Simple operation

The wide variety of applications suitable for VARIOCONTROL is reflected in the simplicity of operation. All settings and other information are displayed on a centrally positioned clear screen, which is used to set and display the type of function, target value or amplitude and to operate the BTM prof measuring system with printer. It's as easy as using a CD recorder. And operating the optional BCM 05 or BCM 05 positioning is just as simple. The touchscreen is used to make all entries.



The complete package: BCM 05 positioning.

BCM 05 positioning connects E_{VIB} measured values with the position data of a differential GPS system. Documentation becomes even more user friendly: No fields have to be defined beforehand and the roller driver does not need to assign his current position to the rolling track. The roller knows exactly where it is.

BCM 05 positioning safeguards documentation against operating errors and manipulation. Compaction is documented in an unbroken chain as with a map.

BOMAG uses the compact and easy to install Starfire iTC® System for DGPS; this system works with a satellite supported reference service and has a positioning accuracy of at least 20 cm. No reference station is needed with this system. However, BCM 05 positioning can also be combined with any other conventional DGPS systems and with systems that use reference stations, which means it can make use of existing site infrastructure.

BOMAG measuring systems meet all specifications for surface covering compaction control. Labour intensive and expensive conventional test methods can be reduced in accordance with local regulations. The advantages are manifold:

- ◆ Meaningful E_{VIB} value
- ◆ Complete documentation
- ◆ Identification of weak spots
- ◆ Reduced compliance testing costs
- ◆ Simple operation
- ◆ Fewer risks



BCM 05 – Complete map-style documentation of compaction.



Surface covering compaction control with GPS. The BOMAG Starfire iTC® System gives high accuracy and requires no local reference station.

Cut your costs per cubic metre every day!

| Example costs for an earthworks project with optimum layer thickness (optimum combination of equipment, excluding labour costs and surcharges) | | |
|---|---|---|
| The project: | Soil compaction, standard density specified; Soil type: Gravel 100.000 m ³ | |
| | BW 213 D | BW 213 DH BVC |
| Formula used for output L_t | $L_t = 60 (b - \ddot{u}) v_a h_g / n$ \ddot{u} = Overlap of rolling tracks (75% of compaction speed) h_g = Layer thickness | b = Working width v_a = Working speed in m/min n = Number of passes |
| Layer thickness in m | 0,50 | 0,80 |
| Calculation of L_t in m ³ /h | 60 (2,13 – 0,13) 0,75 x 50 x 0,5 / 6 | 60 (2,13 – 0,13) 0,75 x 50 x 0,8 / 6 |
| Output in m ³ /h | 375 | 600 |
| Total costs/hour in €/h (excluding labour) | 30,25 | 33,45 |
| Total costs for the compaction of 100.000 m ³ (excluding labour and surcharges) | 8.067 | 5.575 |
| Result: Saved equipment costs using BOMAG VARIOCONTROL single drum rollers: | | 30% |

Table 1: Potential savings achieved by BVC on an earthworks project

| Cost calculation for a typical road project with specified layer thickness (optimum combination of equipment, excluding labour costs and surcharges) | | |
|---|---|---|
| Project description: | Soil compaction, high load bearing capacity specification; Material: anti-frost layer 20.000 m ³ | |
| | BW 213 D | BW 213 DH BVC |
| Output calculation formula L_t | $L_t = 60 (b - \ddot{u}) v_a h_g / n$ \ddot{u} = Overlap of rolling tracks (75% of compaction speed) h_g = Layer thickness | b = Working width v_a = Working speed in m/min n = Number of passes |
| Number of passes | 8 | 6 |
| Calculation of L_t in m ³ /h | 60 (2,13 – 0,13) 0,75 x 50 x 0,3 / 8 | 60 (2,13 – 0,13) 0,75 x 50 x 0,3 / 6 |
| Output in m ³ /h | 165 | 225 |
| Total costs/hour in €/h (excluding labour costs) | 30,25 | 33,45 |
| Total costs for the compaction of 20.000 m ³ (excluding labour costs and surcharges) | 3.580 | 2.973 |
| Result: Saved equipment costs using BOMAG VARIOCONTROL single drum rollers: | | 17% |

Table 2: Potential savings with BVC in road construction



It's profitability that matters – every time.

This is where BOMAG VARIOCONTROL sets the standard. Like any construction operation, compaction costs money. BOMAG VARIOCONTROL cuts these costs with:

- ◆ Higher compaction output
- ◆ Thicker layers
- ◆ No unnecessary passes
- ◆ Higher machine flexibility
- ◆ Increased roller utilization
- ◆ Reduced transport costs
- ◆ Less conventional compliance testing

When estimating potential costs, contractors need to assess the financial risks involved in the contract and any liability for defects. With VARIOCONTROL and integrated measuring systems, contractors can minimize their risks through:

- ◆ Uniform compaction
- ◆ Complete documentation of compaction quality
- ◆ Targeted treatment of weak spots
- ◆ Low vibration compaction

All VARIOCONTROL units come standard equipped with the innovative BOMAG ECOMODE. ECOMODE regulates engine speed to the current load on the machine, reducing fuel consumption by up to 30%.

BOMAG VARIOCONTROL – infinite and automatic adjustment of compaction from low vibration of surfaces to maximum depth penetration.

As on all BOMAG single drum rollers, grease nipples have been eliminated. Extended maintenance intervals and fast access to all service points cut maintenance costs. The result:

- ◆ Less fuel consumption with ECOMODE
- ◆ Reduced maintenance costs
- ◆ Extended service life
- ◆ Improved reliability

BOMAG VARIOCONTROL:

Our innovation – your profit!

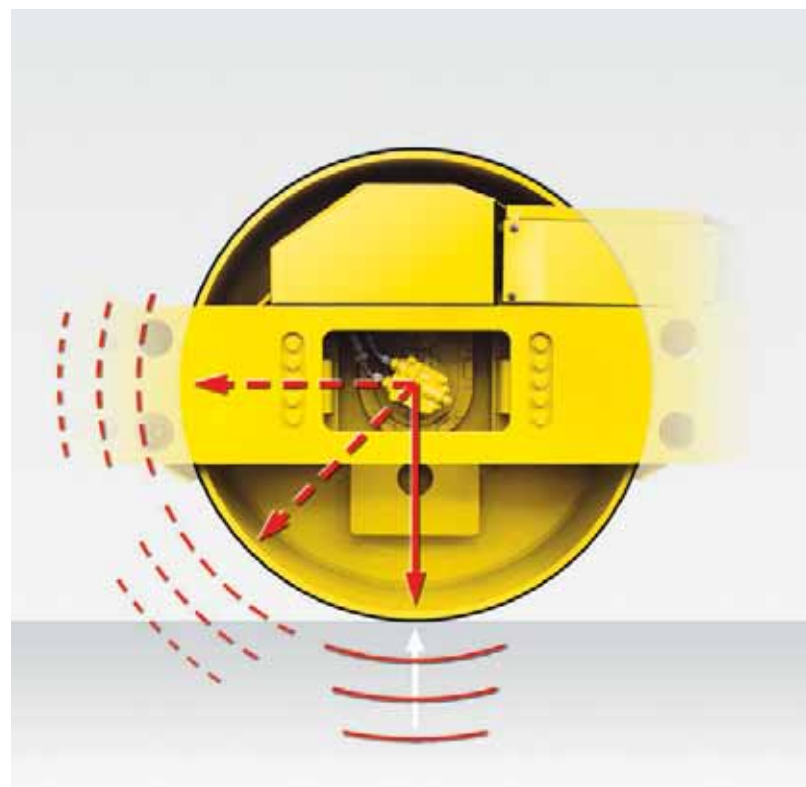

Head Office / Hauptsitz:
BOMAG
Hellerwald
56154 Boppard
GERMANY
Tel. +49 6742 100-0
Fax +49 6742 3090
info@bomag.com

BOMAG Maschinen-
handelsgesellschaft m.b.H.
Porschestraße 9
1230 Wien
AUSTRIA
Tel. +43 1 69040-0
Fax +43 1 69040-20
austria@bomag.com

BOMAG MARINI EQUIPAMENTOS LTDA.
Rua Comendador Clemente Cifali, 530
Distrito Industrial Ritter
Cachoeirinha – RS
BRAZIL
ZIP code 94935-225
Tel. +55 51 2125-6677
Fax +55 51 3470-6220
brasil@bomag.com

BOMAG (CANADA), INC.
3455 Semenik Court
Mississauga, Ontario L5C 4P9
CANADA
Tel. +1 905 361 9961
Fax +1 905 361 9962
canada@bomag.com

BOMAG (CHINA)
Compaction Machinery Co. Ltd.
No. 2808 West Huancheng Road
Shanghai Comprehensive
Industrial Zone (Fengxian)
Shanghai 201401
CHINA
Tel. +86 21 33655566
Fax +86 21 33655508
china@bomag.com

BOMA Equipment
Hong Kong LTD
Room 1003, 10/F Cham Centre
700, Castle Peak Road
Kowloon
HONG KONG
Tel. +852 2721 6363
Fax +852 2721 3212
bomahk@bomag.com

BOMAG France S.A.S.
2, avenue du Général de Gaulle
91170 Viry-Châtillon
FRANCE
Tel. +33 1 69578600
Fax +33 1 69962660
france@bomag.com

BOMAG (GREAT BRITAIN), LTD.
Sheldon Way
Larkfield, Aylesford
Kent ME20 6SE
GREAT BRITAIN
Tel. +44 1622 716611
Fax +44 1622 710233
gb@bomag.com

BOMAG Italia Srl.
Via Roma 50
48011 Alfonsine
ITALY
Tel. +39 0544 864235
Fax +39 0544-864367
italy@bomag.com

FAYAT BOMAG Polska Sp. z o.o.
Ul. Szyszkowa 52
02-285 Warszawa
POLAND
Tel. +48 22 482 04 00
Fax +48 22 482 04 01
poland@bomag.com

FAYAT BOMAG RUS OOO
141400, RF, Moscow region
Khimki, Klayazma block, h. 1-g
RUSSIA
Tel. +7 (495) 287 92 90
Fax +7 (495) 287 92 91
russia@bomag.com

BOMAG GmbH
300 Beach Road
The Concourse, #18-06
Singapore 199555
SINGAPORE
Tel. +65 6 294 1277
Fax +65 6 294 1377
singapore@bomag.com

BOMAG Americas, Inc.
2000 Kentville Road
Kewanee, Illinois 61443
U.S.A.
Tel. +1 309 8533571
Fax +1 309 8520350
usa@bomag.com